



User's Guide

NHD-5.7-320240WFB-ETXI#

LCM

(Liquid Crystal Display Module)

RoHS Compliant

For product support, contact

Newhaven Display International, LLC
2511 Technology Drive, #101
Elgin, IL 60124
Tel: (847) 844-8795 Fax: (847) 844-8796

October 22, 2008



RECORDS OF REVISION			DOC. FIRST ISSUE
VERSION	DATE	REVISED PAGE NO.	SUMMARY
0	2008.04.01		First issue
A	2008.05.27	8	Modify pin2 and pin8

Contents

- 1. Module Classification Information**
- 2. Block Diagram**
- 3. Electrical Characteristics**
- 4. Absolute Maximum Ratings**
- 5. Interface Pin Function**
- 6. Timing Characteristics**
- 7. Optical Characteristics**
- 8. Contour Drawing**
- 9. LED driving conditions**
- 10. Inspection specification**
- 11. software (Register Initiate code)**

1. Module Classification Information

NHD 5.7-320240 WFB - E T X I #

① ② ③ ④ ⑤ ⑥ ⑦ ⑧

① Brand : NEWHAVEN DISPLAY INTERNATIONAL, LLC.

② Display Size: 5.7inch diagonal, 320xRGBx240 pixels

③ Display Type : WFB: TFT

④ Model serials number: **E : with Epson Controller**

⑤ Backlight Type :

N→Without backlight	A→LED, Amber
B→EL, Blue green	R→LED, Red
D→EL, Green	O→LED, Orange
W→EL, White	G→LED, Green
F→CCFL, White	T →LED, White
Y→LED, Yellow Green	S→LED, Bright White

⑥ LCD Mode :

B→TN Positive, Gray	T→FSTN Negative
N→TN Negative,	M→STN Negative, Blue
G→STN Positive, Gray	F→FSTN Positive
Y→STN Positive, Yellow Green	X : TFT, normally white

⑦ LCD Polarizer Type/ Temperature range/ View direction

A→Reflective, N.T, 6:00	H→Transflective, W.T,6:00
D→Reflective, N.T, 12:00	K→Transflective, W.T,12:00
G→Reflective, W. T, 6:00	C→Transmissive, N.T,6:00
J→Reflective, W. T, 12:00	F→Transmissive, N.T,12:00
B→Transflective, N.T,6:00	I →Transmissive, W. T, 6:00
E→Transflective, N.T.12:00	L→Transmissive, W.T,12:00

⑧ Special Code
: RoHS Compliant

This product is composed of a TFT LCD panel, driver ICs, FPC, Control Board and a backlight unit.

Item	Dimension	Unit
Dot Matrix	320 x RGBx240(TFT)	dots
Module dimension	149.0x 109.0 x 11.5 (max)	mm
View area	115.200x 86.40	mm
Dot pitch	0.12 x 0.36	mm
Driving IC package	COG	
LCD type	TFT, Negative, Transmissive	
View direction	6 o'clock	
Backlight Type	LED, Normally White	
Controller IC	SID13A04 - 16 bit mode only	

*Expose the IC number blaze (Luminosity over than 1 cd) when using the LCM may cause IC operating failure.

*Color tone slight changed by temperature and driving voltage.

2. Block Diagram

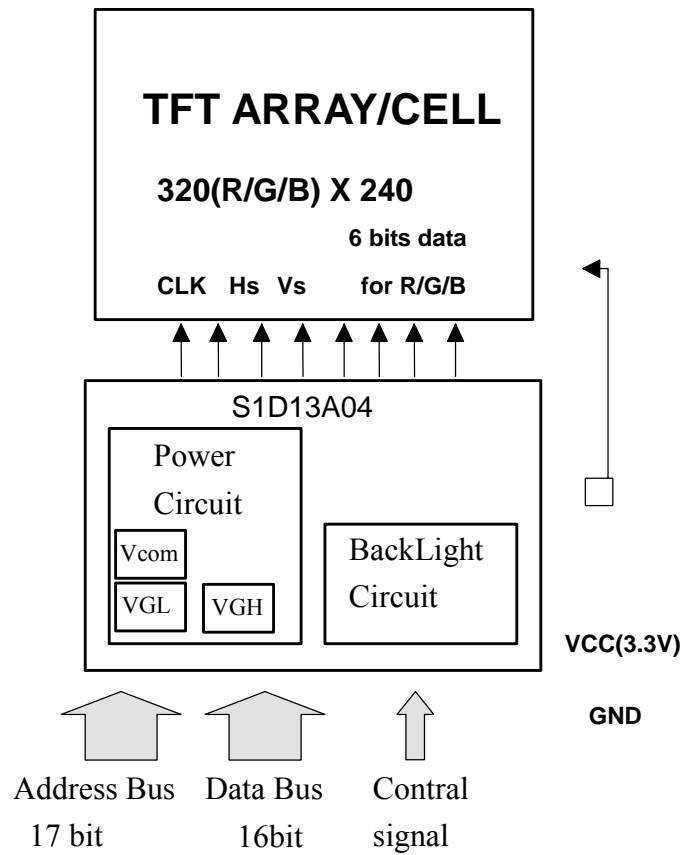

Bit0 ~ Bit4 RED
Bit5 ~ Bit10 GREEN
Bit11~ Bit15 BLUE

3. Electrical Characteristics

Item	Symbol	Condition	Min	Typ	Max	Unit
Supply Voltage For Logic	VCC	—	3.0	3.3	3.6	V
Input High Volt.	V _{IH}	—	0.7 V _{CC}	—	V _{CC}	V
Input Low Volt.	V _{IL}	—	0	—	0.3V _{CC}	V
LCD Driving Supply Voltage	V _{GH} *1	T _a =25°C		15		V *3
	V _{GL} *2			-10		V
	V _{comH}		2.5		5.5	
	V _{comL}		-2.0		0	
Supply Current	I _{VDD}	V _{DD} =3.3V	—	5	8	mA

Notes:

*1) V_{GH} is TFT Gate on operating Voltage.

*2) V_{GL} is TFT Gate off operating Voltage, V_{GL} signal must be fluctuates with same phase as V_{com} when Storage on Gate structure.

*3) V_{com} must be adjusted to optimize display quality_Crosstalk, Contrast Ratio and etc.

4. Absolute Maximum Ratings

Item	Symbol	Min	Typ	Max	Unit
Operating Temperature	T _{OP}	-20	—	+70	°C
Storage Temperature	T _{ST}	-30	—	+80	°C
Power Supply Voltage	V _{GH}	-0.3	—	18	V
	V _{GL}	-15	—	0.3	V
	VCC	-0.3	—	6.0	V

5. Interface Pin Function

5-1 Pins Connection To Control Board

P/N	Symbol	Function	P/N	Symbol	Function
1	Vcc	Power Supply : +3.3V	26	VCC	Power Supply : +3.3V
2	Vcc	Power Supply : +3.3V	27	CLK	Typically used as input clock source for pixel clock . Normally this pin can be floated
3	DB0	Input data from the system data bus.	28	GND	Ground for logic circuit
4	DB1		29	GND	Ground for logic circuit
5	DB2		30	GND	Ground for logic circuit
6	DB3		31	AD1	System address bus bits
7	DB4		32	GND	Ground for logic circuit
8	DB5		33	AD2	System address bus bits
9	DB6		34	GND	Ground for logic circuit
10	DB7		35	AD3	System address bus bits
11	DB8		36	GND	Ground for logic circuit
12	DB9		37	AD4	System address bus bits
13	DB10		38	AD5	
14	DB11		39	AD6	
15	DB12		40	AD7	
16	DB13		41	AD8	
17	DB14		42	AD9	
18	DB15	43	AD10		
19	CS	Chip select input.	44	AD11	
20	MR	See Note(1)	45	AD12	
21	RD	this pin inputs the read command	46	AD13	
22	WR	write enable signal	47	AD14	
23	BHE	This pin inputs the byte enable signal for the high data byte *Note (2)	48	AD15	
24	REST	Active low input to set all internal registers to the default state	49	AD16	
25	WAIT	This pin outputs the wait signal	50	AD17	

Note(1): M/R# is set high to access display buffer, low to access the registers.

Note(2): BHE should be set high, this display supports Little Endian 16-bit mode only.

6. Timing Characteristics

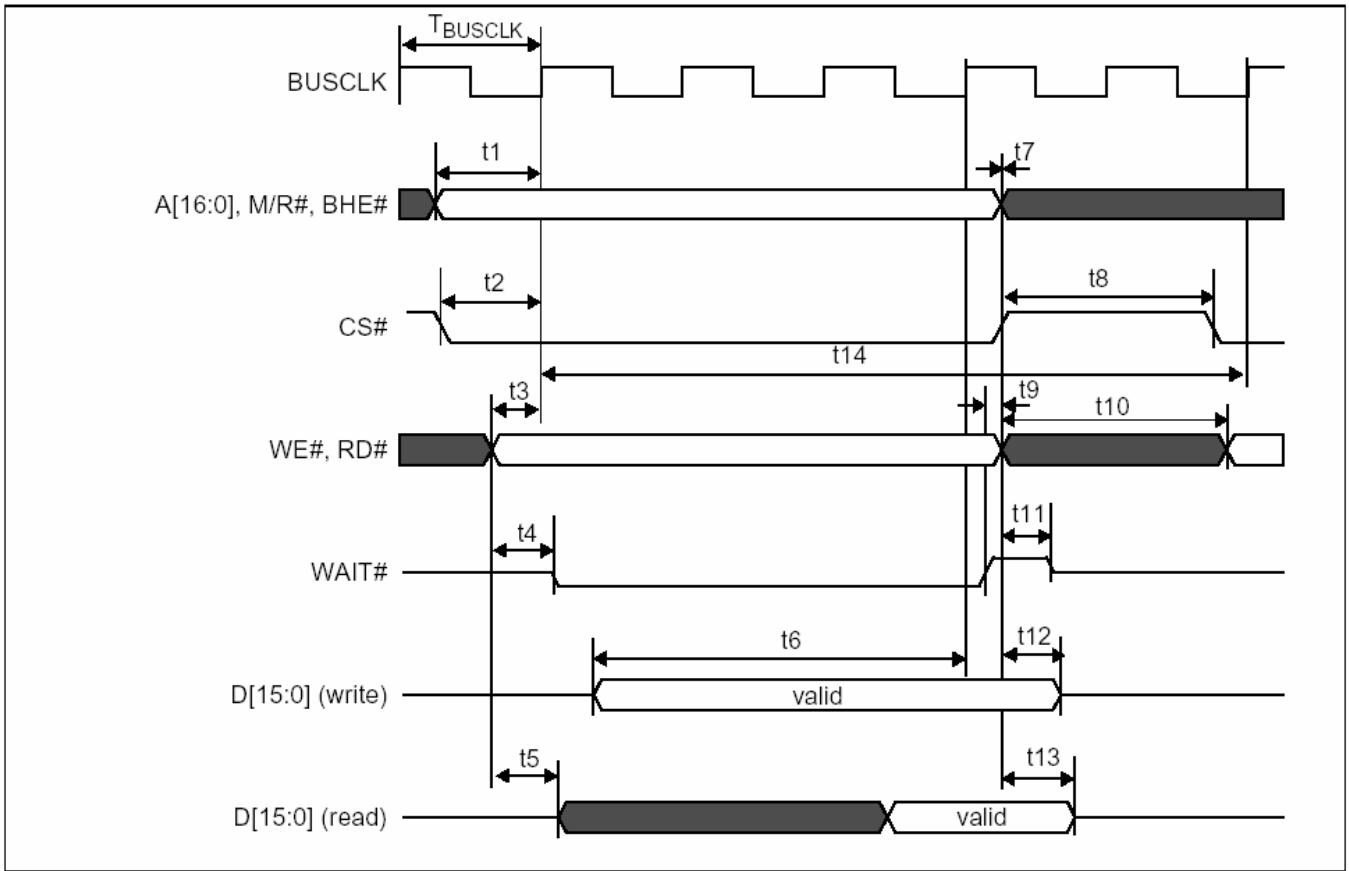

6-1. Interface Timing

Symbol	Parameter	Min	Max	Unit
f_{BUSCLK}	Bus clock frequency		50	MHZ
T_{BUSCLK}	Bus clock period	$1/f_{BUSCLK}$		ns
t_1	A[16:0], M/R#, BHE# setup to first BUSCLK rising edge where CS# = 0 and either RD# = 0 or WE# = 0	9		ns
t_2	CS# setup to BUSCLK rising edge	9		ns
t_3	RD#, WE# setup to BUSCLK rising edge	1		ns
t_4	RD# or WE# state change to WAIT# driven low	1	10	ns
t_5	RD# falling edge to D[15:0] driven (read cycle)	2	10	ns
t_6	D[15:0] setup to 4th rising BUSCLK edge after CS#=0 and WE#=0	1		T_{BUSCLK}
t_7	A[16:0], M/R#, BHE# and CS# hold from RD#, WE# rising edge	0		ns
t_8	CS# deasserted to reasserted	0		ns
t_9	WAIT# rising edge to RD#, WE# rising edge	0		ns
t_{10}	WE#, RD# deasserted to reasserted	1		T_{BUSCLK}
t_{11}	Rising edge of either RD# or WE# to WAIT# high impedance		0.5	T_{BUSCLK}
t_{12}	D[15:0] hold from WE# rising edge (write cycle)	2		ns
t_{13}	D[15:0] hold from RD# rising edge (read cycle)	1		ns
t_{14}	Cycle Length	6		T_{BUSCLK}

7. Optical Characteristics

Ta=25±2°C, ILED=140mA

Item	Symbol	Condition	Min.	Typ.	Max.	Unit	Remark	
Response time	Tr	$\theta=0^\circ$	-	15	30	ms	Note 3,5	
	Tf		-	35	50	ms		
Contrast ratio	CR	At optimized viewing angle	150	200			Note 4,5	
Color Chromaticity	White	$\theta=0^\circ$	Wx	(0.25)	(0.30)	(0.35)		Note 2,6,7
			Wy	(0.27)	(0.32)	(0.37)		
Viewing angle	Hor.	CR≥10	ΘR	50	65	-	Deg.	Note 1
			ΘL	50	65	-		
	Ver.		ΘT	30	50	-		
			ΘB	50	55	-		
Brightness	-	-	300	350	-	cd/m ²	Center of display	

7.1 Definition of optical characteristics

Note 1: Definition of viewing angle

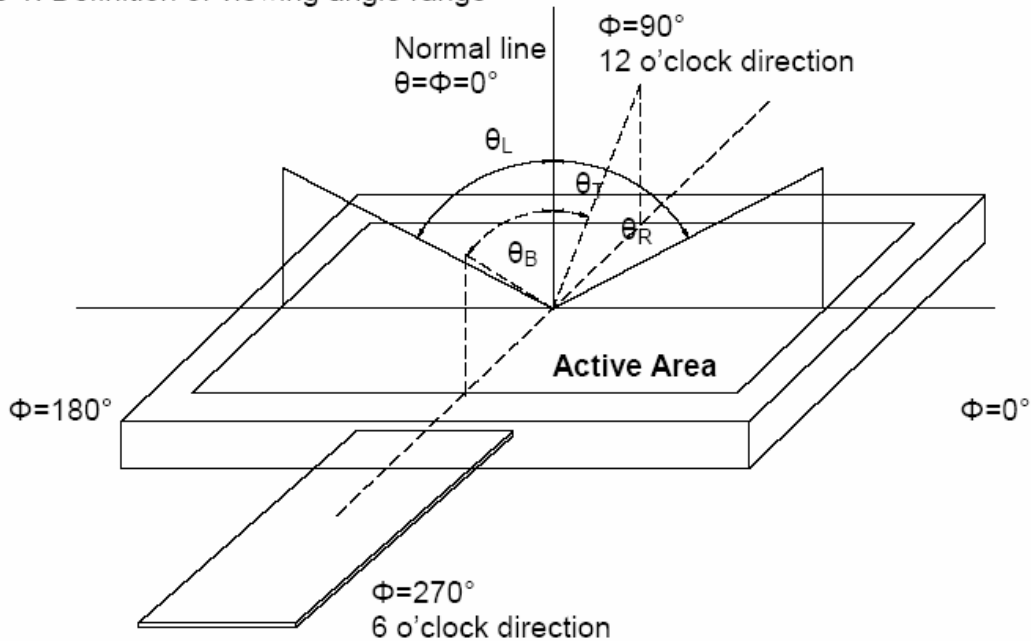

Fig. 5-1 Definition of viewing angle

Note 2: Definition of optical measurement system.

The optical characteristics should be measured in dark room. The optical properties are measured at the center point of the LCD screen. (Response time is measured by Photo detector TOPCON BM-7, other items are measured by BM-5A/Field of view: 1° /Height: 500mm.)

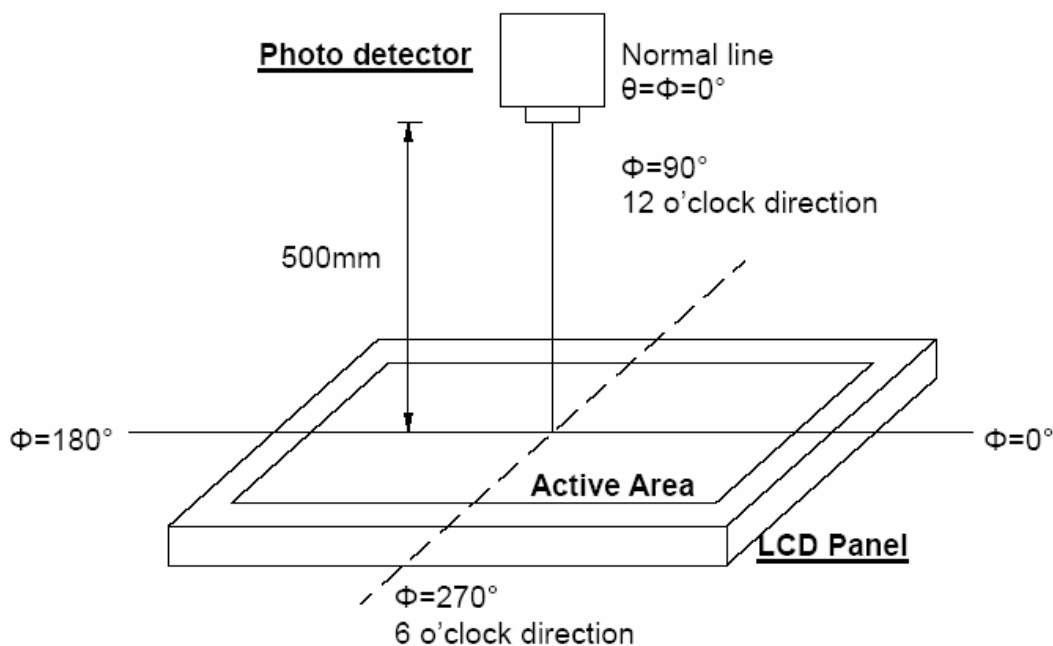

Fig. 5-2 Optical measurement system setup

The copyright belongs to InnoLux. Any unauthorized use is prohibited.

Note 3: Definition of Response time

The response time is defined as the LCD optical switching time interval between "White" state and "Black" state. Rise time (T_{ON}) is the time between photo detector output intensity changed from 90% to 10%. And fall time (T_{OFF}) is the time between photo detector output intensity changed from 10% to 90%.

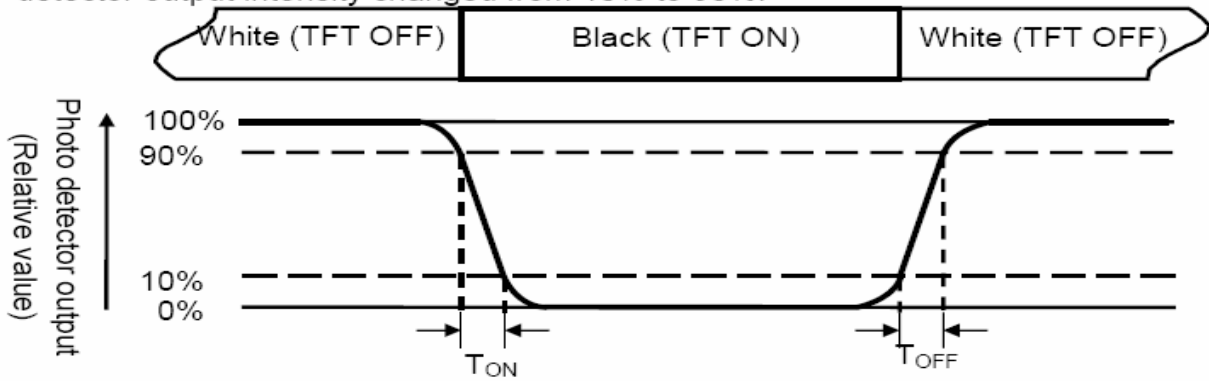

Fig. 5-3 Definition of response time

Note 4: Definition of contrast ratio

$$\text{Contrast ratio (CR)} = \frac{\text{Luminance measured when LCD is on the "White" state}}{\text{Luminance measured when LCD is on the "Black" state}}$$

Note 5: Definition of color chromaticity (CIE1931)

Color coordinates measured at center point of LCD.

Note 6: All input terminals LCD panel must be ground when measuring the center area of the panel.

Note 7: Definition of Luminance Uniformity

To test for uniformity, the tested area, which is inside the active area, is divided into 3 rows and 3 columns. The measurement spot is placed at the center of each box.

$$\text{Luminance Uniformity (Yu)} = \frac{B_{min}}{B_{max}}$$

L-----Active area length W----- Active area width

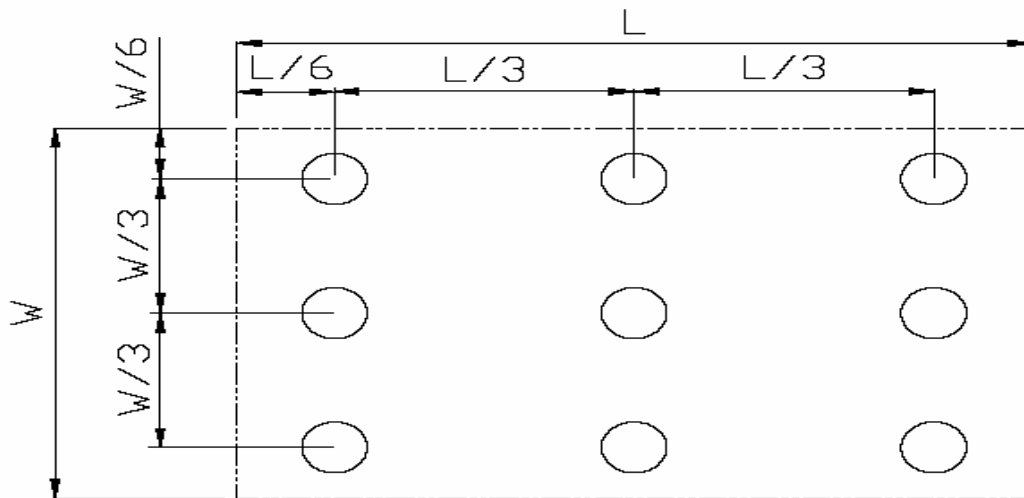
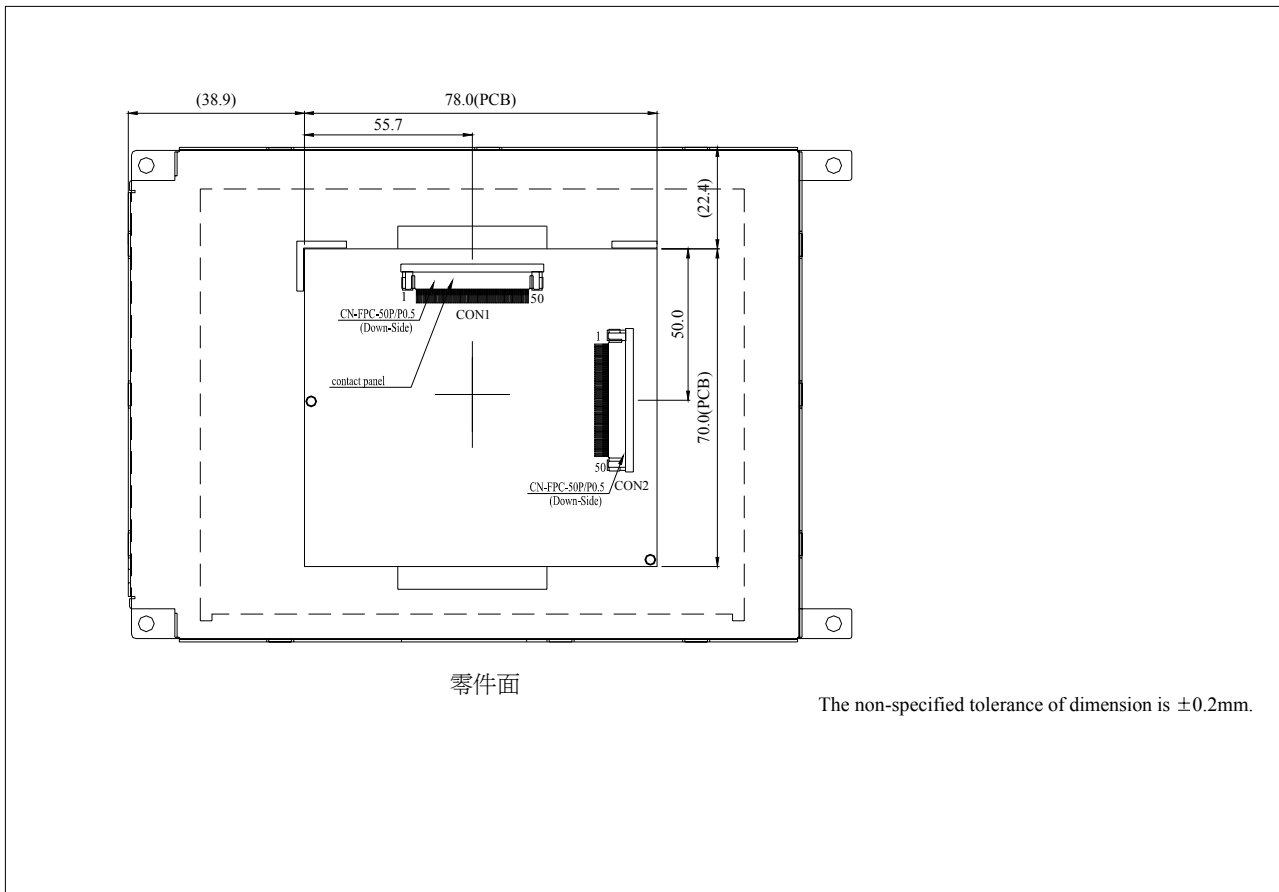
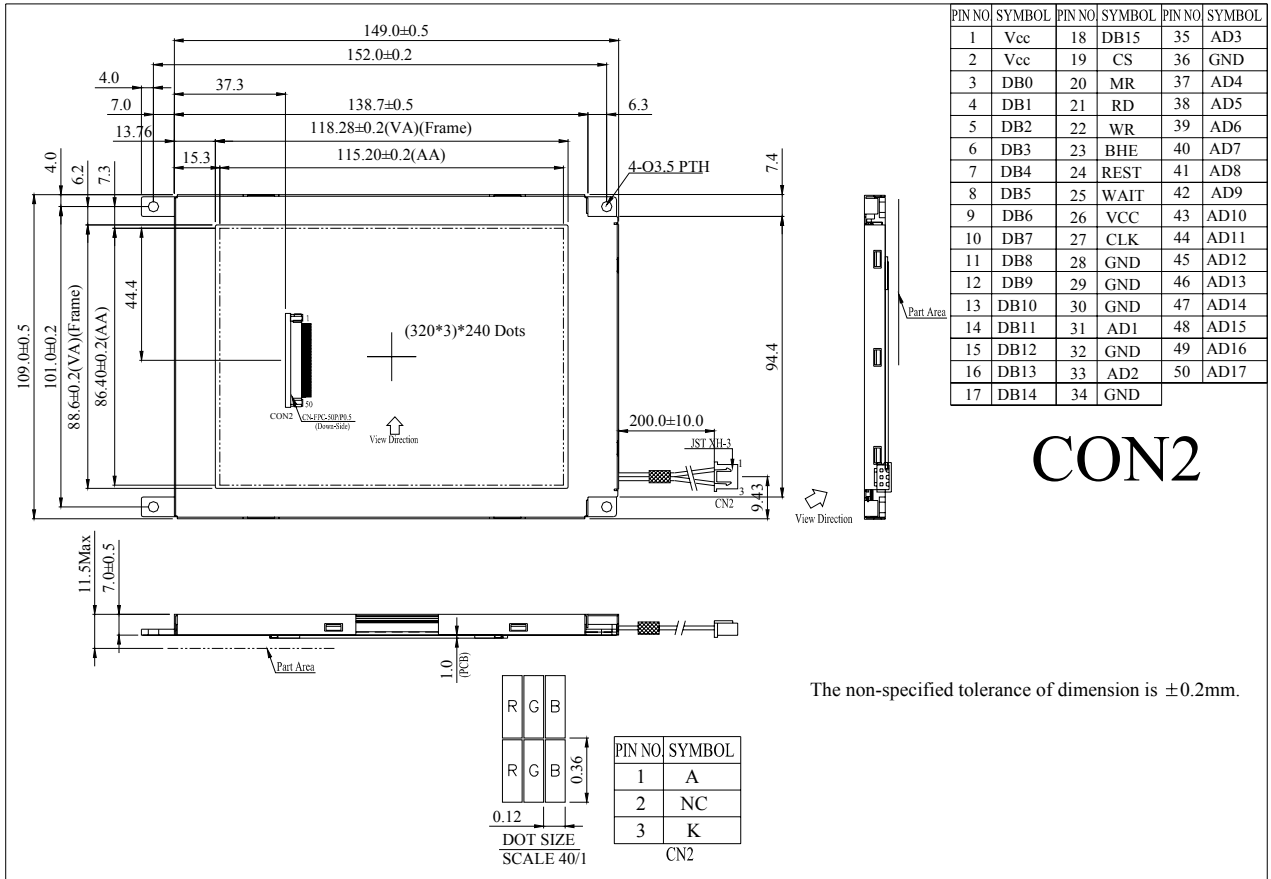

Fig. 5-4 Definition of uniformity

B_{max} : The measured maximum luminance of all measurement position.

B_{min} : The measured minimum luminance of all measurement position.

8. Contour Drawing



9. LED driving conditions

Parameter	Symbol	Min.	Typ.	Max.	Unit	Remark
LED Current	I_{LED}	----	140	210	mA	Note1
LED voltage	V_{LED}	9.0	----	10.5	V	
LED life Time	-	(10,000)	----	----	-	Note 2,3
Luminous Intensity	IV	210.2	262.8	----	CD/M ²	Note 4

Note 1: There are 7 Groups LED shown as below, =9.9 V(Min)

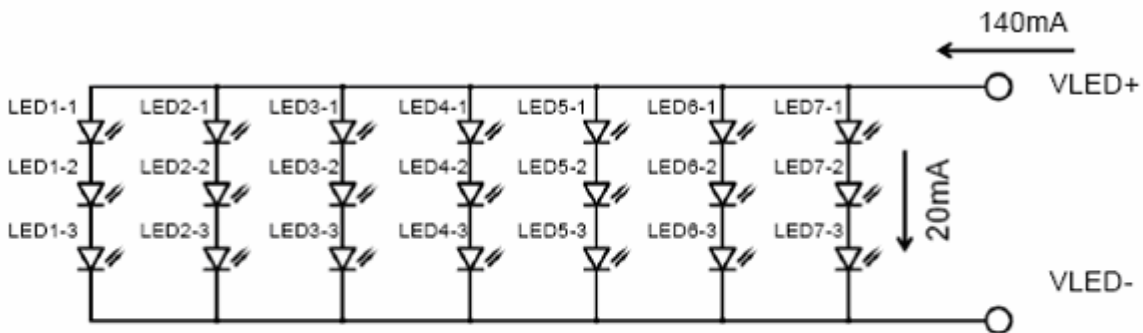

Note 2 : $T_a = 25^{\circ}\text{C}$,

Note 3 : Brightness to be decreased to 50% of the initial value.

Note 4: The luminous is measured through LCD panel.

10. Inspection specification

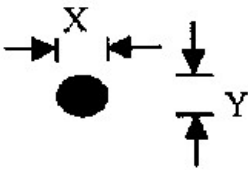
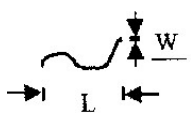
NO	Item	Criterion	AQL													
01	Electrical Testing	1.1 Missing vertical, horizontal segment, segment contrast defect. 1.2 Missing character , dot or icon. 1.3 Display malfunction. 1.4 No function or no display. 1.5 Current consumption exceeds product specifications. 1.6 LCD viewing angle defect. 1.7 Mixed product types. 1.8 Contrast defect.	0.65													
02	Black or white spots on LCD (display only)	2.1 White and black spots on display $\leq 0.25\text{mm}$, no more than three white or black spots present. 2.2 Densely spaced: No more than two spots or lines within 3mm	2.5													
03	LCD black spots, white spots, contamination (non-display)	3.1 Round type : As following drawing $\Phi = (x + y) / 2$  <table border="1" data-bbox="874 929 1353 1142"> <thead> <tr> <th>SIZE</th> <th>Acceptable Q TY</th> </tr> </thead> <tbody> <tr> <td>$\Phi \leq 0.10$</td> <td>Accept no dense</td> </tr> <tr> <td>$0.10 < \Phi \leq 0.20$</td> <td>2</td> </tr> <tr> <td>$0.20 < \Phi \leq 0.25$</td> <td>1</td> </tr> <tr> <td>$0.25 < \Phi$</td> <td>0</td> </tr> </tbody> </table>	SIZE	Acceptable Q TY	$\Phi \leq 0.10$	Accept no dense	$0.10 < \Phi \leq 0.20$	2	$0.20 < \Phi \leq 0.25$	1	$0.25 < \Phi$	0	2.5			
		SIZE	Acceptable Q TY													
$\Phi \leq 0.10$	Accept no dense															
$0.10 < \Phi \leq 0.20$	2															
$0.20 < \Phi \leq 0.25$	1															
$0.25 < \Phi$	0															
3.2 Line type : (As following drawing)  <table border="1" data-bbox="710 1220 1353 1429"> <thead> <tr> <th>Length</th> <th>Width</th> <th>Acceptable Q TY</th> </tr> </thead> <tbody> <tr> <td>---</td> <td>$W \leq 0.02$</td> <td>Accept no dense</td> </tr> <tr> <td>$L \leq 3.0$</td> <td>$0.02 < W \leq 0.03$</td> <td rowspan="2">2</td> </tr> <tr> <td>$L \leq 2.5$</td> <td>$0.03 < W \leq 0.05$</td> </tr> <tr> <td>---</td> <td>$0.05 < W$</td> <td>As round type</td> </tr> </tbody> </table>	Length	Width	Acceptable Q TY	---	$W \leq 0.02$	Accept no dense	$L \leq 3.0$	$0.02 < W \leq 0.03$	2	$L \leq 2.5$	$0.03 < W \leq 0.05$	---	$0.05 < W$	As round type	2.5	
Length	Width	Acceptable Q TY														
---	$W \leq 0.02$	Accept no dense														
$L \leq 3.0$	$0.02 < W \leq 0.03$	2														
$L \leq 2.5$	$0.03 < W \leq 0.05$															
---	$0.05 < W$	As round type														
04	Polarizer bubbles	If bubbles are visible, judge using black spot specifications, not easy to find, must check in specify direction.	<table border="1" data-bbox="842 1482 1353 1731"> <thead> <tr> <th>Size Φ</th> <th>Acceptable Q TY</th> </tr> </thead> <tbody> <tr> <td>$\Phi \leq 0.20$</td> <td>Accept no dense</td> </tr> <tr> <td>$0.20 < \Phi \leq 0.50$</td> <td>3</td> </tr> <tr> <td>$0.50 < \Phi \leq 1.00$</td> <td>2</td> </tr> <tr> <td>$1.00 < \Phi$</td> <td>0</td> </tr> <tr> <td>Total Q TY</td> <td>3</td> </tr> </tbody> </table>	Size Φ	Acceptable Q TY	$\Phi \leq 0.20$	Accept no dense	$0.20 < \Phi \leq 0.50$	3	$0.50 < \Phi \leq 1.00$	2	$1.00 < \Phi$	0	Total Q TY	3	2.5
Size Φ	Acceptable Q TY															
$\Phi \leq 0.20$	Accept no dense															
$0.20 < \Phi \leq 0.50$	3															
$0.50 < \Phi \leq 1.00$	2															
$1.00 < \Phi$	0															
Total Q TY	3															

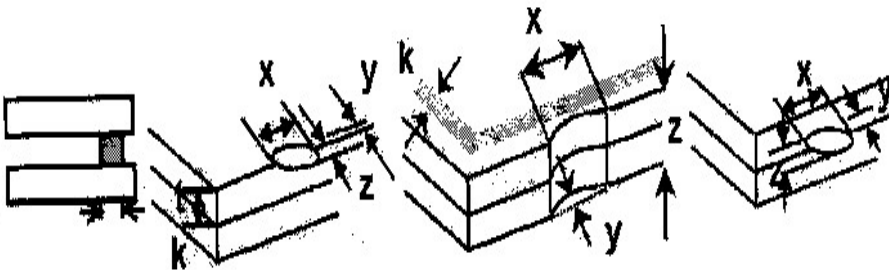
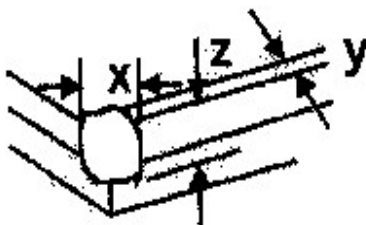
NO	Item	Criterion	AQL																		
05	Scratches	Follow NO.3 LCD black spots, white spots, contamination																			
06	Chipped glass	<p>Symbols Define: x: Chip length y: Chip width z: Chip thickness k: Seal width t: Glass thickness a: LCD side length L: Electrode pad length:</p> <p>6.1 General glass chip : 6.1.1 Chip on panel surface and crack between panels:</p>  <table border="1" data-bbox="443 757 1353 887"> <thead> <tr> <th>z: Chip thickness</th> <th>y: Chip width</th> <th>x: Chip length</th> </tr> </thead> <tbody> <tr> <td>$Z \leq 1/2t$</td> <td>Not over viewing area</td> <td>$x \leq 1/8a$</td> </tr> <tr> <td>$1/2t < z \leq 2t$</td> <td>Not exceed 1/3k</td> <td>$x \leq 1/8a$</td> </tr> </tbody> </table> <p>⊙If there are 2 or more chips, x is total length of each chip.</p> <p>6.1.2 Corner crack:</p>  <table border="1" data-bbox="443 1279 1353 1408"> <thead> <tr> <th>z: Chip thickness</th> <th>y: Chip width</th> <th>x: Chip length</th> </tr> </thead> <tbody> <tr> <td>$Z \leq 1/2t$</td> <td>Not over viewing area</td> <td>$x \leq 1/8a$</td> </tr> <tr> <td>$1/2t < z \leq 2t$</td> <td>Not exceed 1/3k</td> <td>$x \leq 1/8a$</td> </tr> </tbody> </table> <p>⊙If there are 2 or more chips, x is the total length of each chip.</p>	z: Chip thickness	y: Chip width	x: Chip length	$Z \leq 1/2t$	Not over viewing area	$x \leq 1/8a$	$1/2t < z \leq 2t$	Not exceed 1/3k	$x \leq 1/8a$	z: Chip thickness	y: Chip width	x: Chip length	$Z \leq 1/2t$	Not over viewing area	$x \leq 1/8a$	$1/2t < z \leq 2t$	Not exceed 1/3k	$x \leq 1/8a$	2.5
z: Chip thickness	y: Chip width	x: Chip length																			
$Z \leq 1/2t$	Not over viewing area	$x \leq 1/8a$																			
$1/2t < z \leq 2t$	Not exceed 1/3k	$x \leq 1/8a$																			
z: Chip thickness	y: Chip width	x: Chip length																			
$Z \leq 1/2t$	Not over viewing area	$x \leq 1/8a$																			
$1/2t < z \leq 2t$	Not exceed 1/3k	$x \leq 1/8a$																			

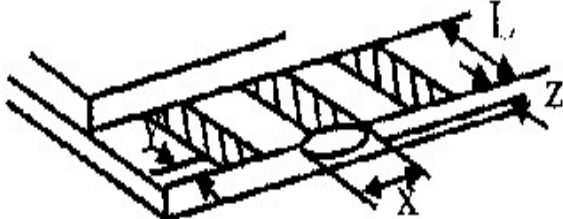
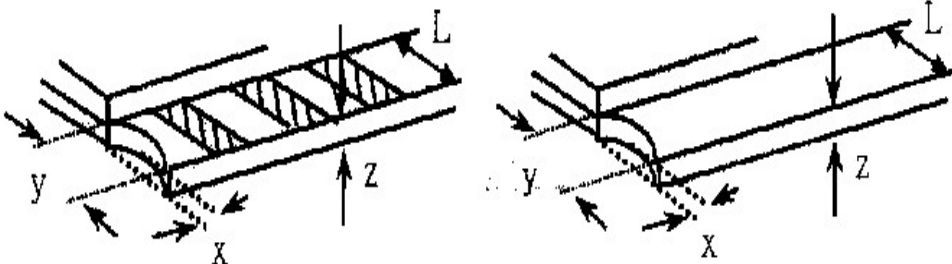
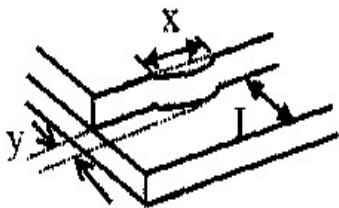
NO	Item	Criterion	AQL																
06	Glass crack	<p>Symbols :</p> <p>x: Chip length y: Chip width z: Chip thickness k: Seal width t: Glass thickness a: LCD side length L: Electrode pad length</p> <p>6.2 Protrusion over terminal :</p> <p>6.2.1 Chip on electrode pad :</p>  <table border="1" data-bbox="354 656 1265 741"> <tr> <td>y: Chip width</td> <td>x: Chip length</td> <td>z: Chip thickness</td> </tr> <tr> <td>$y \leq 0.5\text{mm}$</td> <td>$x \leq 1/8a$</td> <td>$0 < z \leq t$</td> </tr> </table> <p>6.2.2 Non-conductive portion:</p>  <table border="1" data-bbox="426 1075 1265 1160"> <tr> <td>y: Chip width</td> <td>x: Chip length</td> <td>z: Chip thickness</td> </tr> <tr> <td>$y \leq L$</td> <td>$x \leq 1/8a$</td> <td>$0 < z \leq t$</td> </tr> </table> <p>⊙ If the chipped area touches the ITO terminal, over 2/3 of the ITO must remain and be inspected according to electrode terminal specifications.</p> <p>⊙ If the product will be heat sealed by the customer, the alignment mark not be damaged.</p> <p>6.2.3 Substrate protuberance and internal crack.</p>  <table border="1" data-bbox="762 1384 1272 1469"> <tr> <td>y: width</td> <td>x: length</td> </tr> <tr> <td>$y \leq 1/3L$</td> <td>$x \leq a$</td> </tr> </table>	y: Chip width	x: Chip length	z: Chip thickness	$y \leq 0.5\text{mm}$	$x \leq 1/8a$	$0 < z \leq t$	y: Chip width	x: Chip length	z: Chip thickness	$y \leq L$	$x \leq 1/8a$	$0 < z \leq t$	y: width	x: length	$y \leq 1/3L$	$x \leq a$	2.5
y: Chip width	x: Chip length	z: Chip thickness																	
$y \leq 0.5\text{mm}$	$x \leq 1/8a$	$0 < z \leq t$																	
y: Chip width	x: Chip length	z: Chip thickness																	
$y \leq L$	$x \leq 1/8a$	$0 < z \leq t$																	
y: width	x: length																		
$y \leq 1/3L$	$x \leq a$																		

NO	Item	Criterion	AQL
07	Cracked glass	The LCD with extensive crack is not acceptable.	2.5
08	Backlight elements	8.1 Illumination source flickers when lit. 8.2 Spots or scratched that appear when lit must be judged. Using LCD spot, lines and contamination standards. 8.3 Backlight doesn't light or color wrong.	0.65 2.5 0.65
09	Bezel	9.1 Bezel may not have rust, be deformed or have fingerprints, stains or other contamination. 9.2 Bezel must comply with job specifications.	2.5 0.65
10	PCB、COB	10.1 COB seal may not have pinholes larger than 0.2mm or contamination. 10.2 COB seal surface may not have pinholes through to the IC. 10.3 The height of the COB should not exceed the height indicated in the assembly diagram. 10.4 There may not be more than 2mm of sealant outside the seal area on the PCB. And there should be no more than three places. 10.5 No oxidation or contamination PCB terminals. 10.6 Parts on PCB must be the same as on the production characteristic chart. There should be no wrong parts, missing parts or excess parts. 10.7 The jumper on the PCB should conform to the product characteristic chart. 10.8 If solder gets on bezel tab pads, LED pad, zebra pad or screw hold pad, make sure it is smoothed down.	2.5 2.5 0.65 2.5 2.5 0.65 0.65 2.5
11	Soldering	11.1 No un-melted solder paste may be present on the PCB. 11.2 No cold solder joints, missing solder connections, oxidation or icicle. 11.3 No residue or solder balls on PCB. 11.4 No short circuits in components on PCB.	2.5 2.5 2.5 0.65

NO	Item	Criterion	AQL
12	General appearance	12.1 No oxidation, contamination, curves or, bends on interface Pin (OLB) of TCP.	2.5
		12.2 No cracks on interface pin (OLB) of TCP.	0.65
		12.3 No contamination, solder residue or solder balls on product.	2.5
		12.4 The IC on the TCP may not be damaged, circuits.	2.5
		12.5 The uppermost edge of the protective strip on the interface pin must be present or look as if it cause the interface pin to sever.	2.5
		12.6 The residual rosin or tin oil of soldering (component or chip component) is not burned into brown or black color.	2.5
		12.7 Sealant on top of the ITO circuit has not hardened.	0.65
		12.8 Pin type must match type in specification sheet.	0.65
		12.9 LCD pin loose or missing pins.	0.65
		12.10 Product packaging must the same as specified on packaging specification sheet.	0.65
		12.11 Product dimension and structure must conform to product specification sheet.	

11. software (Register Initiate code)

```

{ \
{ 0x14,          0x00000000 }, /* Power Save Configuration Register */ \
{ 0x64,          0x28D70000 }, /* GPIO Status and Control Register */ \
{ 0x04,          0x00000000 }, /* Memory Clock Configuration Register */ \
{ 0x08,          0x00000032 }, /* Pixel Clock Configuration Register */ \
{ 0x0C,          0x00000061 }, /* Panel Type and MOD Rate Register */ \
{ 0x10,          0x00000010 }, /* Display Settings Register */ \
{ 0x20,          0x00000030 }, /* Horizontal Total Register */ \
{ 0x24,          0x00000027 }, /* Horizontal Display Period Register */ \
{ 0x28,          0x0000000F }, /* Horizontal Display Period Start Position Register */ \
{ 0x2C,          0x00870156 }, /* FPLINE Register */ \
{ 0x30,          0x00000103 }, /* Vertical Total Register */ \
{ 0x34,          0x000000EF }, /* Vertical Display Period Register */ \
{ 0x38,          0x00000013 }, /* Vertical Display Period Start Position Register */ \
{ 0x3C,          0x00800000 }, /* FPFRAME Register */ \
{ 0x40,          0x00000000 }, /* Main Window Display Start Address Register */ \
{ 0x44,          0x000000A0 }, /* Main Window Line Address Offset Register */ \
{ 0x50,          0x00000000 }, /* PIP+ Window Display Start Address Register */ \
{ 0x54,          0x000000A0 }, /* PIP+ Window Line Address Offset Register */ \
{ 0x58,          0x00000000 }, /* PIP+ Window X Positions Register */ \
{ 0x5C,          0x00000000 }, /* PIP+ Window Y Positions Register */ \
{ 0x60,          0x00000000 }, /* Special Purpose Register */ \
{ 0x70,          0x00000000 }, /* PWM Clock Configuration Register */ \
{ 0x74,          0x00000000 }, /* PWMOOUT Duty Cycle Register */ \
{ 0x80,          0x00000000 }, /* Scratch Pad A Register */ \
{ 0x84,          0x00000000 }, /* Scratch Pad B Register */ \
{ 0x88,          0x00000000 }, /* Scratch Pad C Register */ \
{ SID_REGDELAYON, 0x00000032 }, /* LCD Panel Power On Delay (in ms) */ \
{ 0x64,          0x28D70001 }, /* GPIO Status and Control Register */ \
{ 0x14,          0x00000000 } /* Power Save Configuration Register */ \
}

```

Newhaven **LCM Sample Estimate Feedback Sheet**

Module Number : _____

Page: 1

1、Panel Specification :

1. Panel Type : Pass NG , _____
2. View Direction : Pass NG , _____
3. Numbers of Dots : Pass NG , _____
4. View Area : Pass NG , _____
5. Active Area : Pass NG , _____
6. Operating Temperature : Pass NG , _____
7. Storage Temperature : Pass NG , _____
8. Others : _____

2、Mechanical Specification :

1. PCB Size : Pass NG , _____
2. Frame Size : Pass NG , _____
3. Material of Frame : Pass NG , _____
4. Connector Position : Pass NG , _____
5. Fix Hole Position : Pass NG , _____
6. Backlight Position : Pass NG , _____
7. Thickness of PCB : Pass NG , _____
8. Height of Frame to PCB : Pass NG , _____
9. Height of Module : Pass NG , _____
10. Others : Pass NG , _____

3、Relative Hole Size :

1. Pitch of Connector : Pass NG , _____
2. Hole size of Connector : Pass NG , _____
3. Mounting Hole size : Pass NG , _____
4. Mounting Hole Type : Pass NG , _____
5. Others : Pass NG , _____

4、Backlight Specification :

1. B/L Type : Pass NG , _____
2. B/L Color : Pass NG , _____
3. B/L Driving Voltage (Reference for LED Type) : Pass NG , _____
4. B/L Driving Current : Pass NG , _____
5. Brightness of B/L : Pass NG , _____
6. B/L Solder Method : Pass NG , _____
7. Others : Pass NG , _____

>> **Go to page 2** <<

5、Electronic Characteristics of Module :

- | | | |
|------------------------------|-------------------------------|-------------------------------------|
| 1. Input Voltage : | <input type="checkbox"/> Pass | <input type="checkbox"/> NG , _____ |
| 2. Supply Current : | <input type="checkbox"/> Pass | <input type="checkbox"/> NG , _____ |
| 3. Driving Voltage for LCD : | <input type="checkbox"/> Pass | <input type="checkbox"/> NG , _____ |
| 4. Contrast for LCD : | <input type="checkbox"/> Pass | <input type="checkbox"/> NG , _____ |
| 5. B/L Driving Method : | <input type="checkbox"/> Pass | <input type="checkbox"/> NG , _____ |
| 6. Negative Voltage Output : | <input type="checkbox"/> Pass | <input type="checkbox"/> NG , _____ |
| 7. Interface Function : | <input type="checkbox"/> Pass | <input type="checkbox"/> NG , _____ |
| 8. LCD Uniformity : | <input type="checkbox"/> Pass | <input type="checkbox"/> NG , _____ |
| 9. ESD test : | <input type="checkbox"/> Pass | <input type="checkbox"/> NG , _____ |
| 10. Others : | <input type="checkbox"/> Pass | <input type="checkbox"/> NG , _____ |

6、Summary :

Sales signature : _____

Customer Signature : _____

Date : ____ / ____ / ____